

UYA 4Y.KO Mass Comparator

Class-leading manual mass comparator



UYA 5.4Y.KO



Auto-open weighing chamber





External anti-draft chamber

Functions

- 

Mass comparator
- 

Ambient conditions measurement
- 

Proximity sensors
- 

Replaceable units
- 

Multilingual menu
- 

Autotest
- 

Automatic sliding door

Features

Effective and Excellent Measurement

UYA 4Y.KO mass comparators allow to compare 1 mg - 5 g weights of class E1 and lower. The devices are characterised by the highest repeatability, 0.1 µg.

Maximum Comfort of Operation

UYA 4Y.KO mass comparators are equipped with an auto-open weighing chamber that is highly resistant to air drafts. The chamber is made of glass, this makes the compared weight visible from any angle.







Excellent Measurement Repeatability

Each UYA 4Y.KO mass comparator is equipped with an additional external anti-draft chamber by standard, use of this accessory allows to minimize the influence of temperature change and air drafts on the measurements. Since all the external chamber components are made of either glass or metal the effect exerted by an electrostatic field on the weighing result is reduced.

Dedicated Software

Specially designed RMCS computer software enables comprehensive realisation of calibration procedures in laboratory. The system manages the whole calibration process, starting from the moment the order is placed, through procedure performance, to the moment of issuing the calibration certificate.

Technical Specifications

| | | UYA 5.4Y.KO |
|---|---|------------------------------------|
| OIML calibration range E1 |  | 1 mg ÷ 5 g |
| OIML calibration range E2 |  | 1 mg ÷ 5 g |
| OIML calibration range F1 |  | 1 mg ÷ 5 g |
| OIML calibration range F2 |  | 1 mg ÷ 5 g |
| OIML calibration range M1 |  | 1 mg ÷ 5 g |
| OIML calibration range M2 |  | 1 mg ÷ 5 g |
| Maximum capacity [Max] | | 5.1 g |
| Readability [d] | | 0.1 µg |
| Standard repeatability [5% Max]* | | 0.2 µg |
| Standard repeatability [Max] * | | 0.4 µg |
| Permissible repeatability * | | 0.6 µg |
| Stabilization time | | 30 s |
| Adjustment | | internal |
| Electric compensation range | | 0 ÷ 5.1 g |
| Eccentricity (for test weight) | | 1 d / 1 mm |
| Display | | 5.7" colour resistive touch screen |
| Keypad | | 8 keys |
| Ingress protection - indicator | | IP 43 |
| Touch-free operation | | 2 programmable sensors |
| USB-A | | 2 |
| Ethernet | | 10 / 100 Mbit |
| RS 232 | | 2 |
| Wi-Fi® | | 802.11 b/g/n |
| IN/OUT | | 4 × IN, 4 × OUT |
| Power supply | | 110 ÷ 230 V AC / 50 ÷ 60 Hz |
| Operating temperature | | +15 ÷ +30 °C |
| Operating temperature change rate | | ±0.5 °C / 12 h (± 0.3 °C / 4 h) |
| Relative humidity variations | | ±2% / 12 h |
| Relative humidity*** | | 40 ÷ 80% |
| Transport and storage temperature | | -20 ÷ +50 °C |
| Weighing pan dimensions | | Ø 16 mm |
| Mass comparator dimensions*** | | 411 × 163 × 183 mm |
| Indicator dimensions*** | | 206 × 140 × 70 mm |
| Anti-draft chamber | | standard |
| Anti-draft chamber dimensions*** | | 560 × 250 × 350 mm |
| Mass comparator net weight | | 9.1 kg |
| Mass comparator gross weight | | 16.6 kg |
| Anti-draft chamber net weight | | 7.6 kg |
| Anti-draft chamber gross weight | | 10.9 kg |
| Mass comparator packaging dimensions** | | 660 × 660 × 455 mm |
| Anti-draft chamber packaging dimensions** | | 820 × 840 × 630 mm |

* repeatability is expressed as a standard deviation determined for 6 ABBA cycles

** non-condensing conditions

*** dimensions: length x width x depth

Wi-Fi® is a registered trademark of Wi-Fi® Alliance.

Dimensions

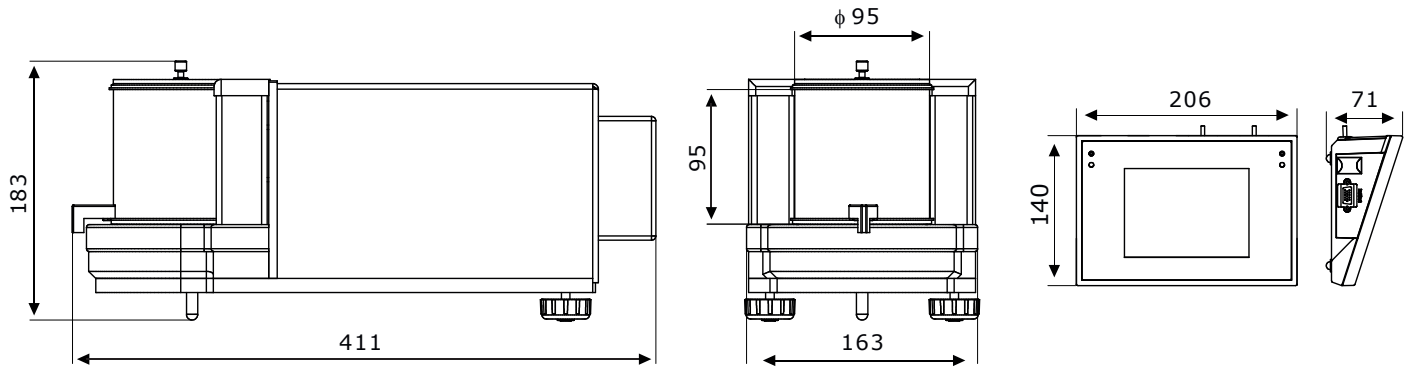

UYA-4Y-KO

Accessories

Weighing Tables

- granite anti-vibration table
- anti-vibration table for laboratory balances
- professional weighing table

Ambient Conditions

- THB-S or THB-P sensor

Peripheral Devices

- Epson dot matrix printer
- barcode scanner
- WD-5/3Y LCD display (backlit)

Cables, Converters

- RS-232 – P0108 computer cable
- RS-232 – P0167 computer cable
- RS-232 – P0151 Epson printer cable

Electrical Accessories

- power supply with ZR-02 battery

Anti-Draft Chambers

- MYA anti-draft chamber

Dedicated Software

RMCS System

- performance of calibration procedures in a laboratory from the moment the order is placed, to the moment of issuing a calibration certificate
- compatible with THB sensors enabling recording ambient conditions
- export of report results to various files
- archiving calibration protocols, orders, certificates and ambient conditions

RADWAG Remote Desktop

- remote control of the mass comparator using computer, telephone or tablet
- sending text messages
- version for Windows 10 and Android systems

R-LAB

- collecting measurements
- carrying out statistical analysis of measurements
- customized graphs and reports

Parameters Editor

- remote change of parameters
- remote on-line preview of the display
- displaying current mass indication
- software update
- file loading, editing and saving parameters to a file
- import and export of parameters
- interfaces: RS232, Ethernet and Wireless Connection
- quick and easy edition of balance parameters using computer