

PUE C315 Indicator

Standard weighing and mobility for vast range of applications



PUE C315



Possibility to mount the indicator to the wall



Communication interfaces

Functions

- Parts counting
- Percent weighing
- Totalizing
- In-built battery
- Replaceable units
- +/- Control
- Animal weighing
- Peak hold
- Alibi memory

Features

Indicator for Industry

The PUE C315 indicator is intended for fast and precise presentation of mass measurement result. Taring available for the whole weighing range allows to swiftly and precisely determine net mass of weighed loads. An ABS plastic housing ensures durability and lightness of the construction.

Uncomplicated Operation and Clear Presentation of Indications

A clear 6-digit LCD display with backlight and pictograms provides clearly visible measurement result. Easy operation enables fast and reliable measurements to be carried out even by an inexperienced operator.

Mobility due to an Internal Battery

In addition to power supply from the mains, PUE C315 indicator is equipped with internal battery that enables several hours long mobile operation.

Versatility of Use

Various possibilities of fastening of the PUE C315 indicator to the weighing platform enable selecting appropriate solution for different places of operation. The indicator can be mounted next to the platform, on a post or using cable.

ALIBI Memory

Internal ALIBI memory guarantees safety and automatic record of measurements copies, it also offers possibility to preview, copy and archive data.

Technical Specifications

	PUE C315
Maximum quantity of verification units [e]	6000
OIML class	III lub IV
Maximum signal gain	19,2 mV
Maximum voltage per verification unit	3,25 μ V
Minimum voltage per verification unit	0,4 μ V
Minimum load cells impedance	50 Ω
Maximum load cells impedance	1200 Ω
Supply voltage of load cell	5V DC
Load cells wiring	4 or 6 wires + shield
Multi range	2 ranges
Housing	ABS housing
Ingress protection	IP 43
Display	LCD (with backlight)
Keypad	microswitch
Keys quantity	5
Additional display	WD-4/1*
RS 232	1
RS 232**	1
Power supply	100 ÷ 240 V AC 50 ÷ 60 Hz / 12 V DC / battery*
Power supply method	a detachable power supply, NiMH 6xAA batteries
Battery operating time	8 h (average time)
Power consumption	5 W
Operating temperature	-10 ÷ +40 °C
Relative humidity **	10 ÷ 80%
Transport and storage temperature	-10 ÷ +50 °C
Overall dimensions	181 × 136 × 60 mm
Net weight	0,6 kg
Gross weight	1,2 kg
Packaging dimensions	220 × 190 × 90 mm

* optional version

** non-condensing conditions

Dimensions

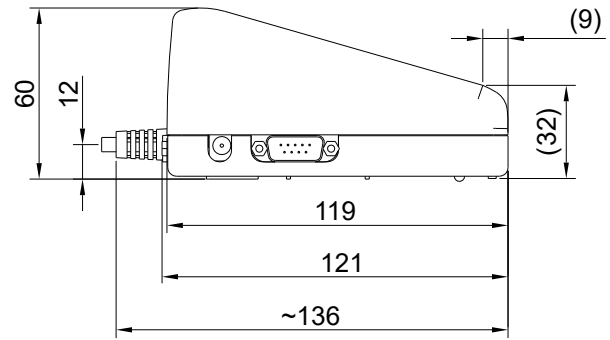
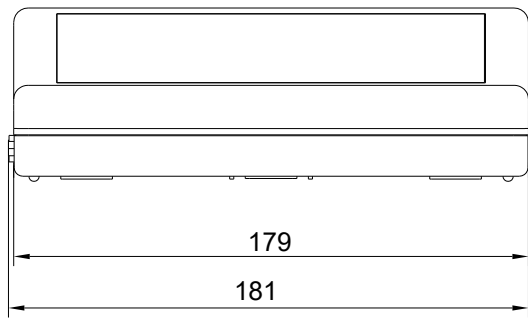

Accessories

Peripheral Devices

- drukarka igłowa Epson
- LCD – WD-4/1 display (backlit)

Cables, Converters

- RS-232 – P0108 computer cable
- RS-232 – P0151 Epson printer cable
- RS232 – KR-04-1 converter

- RS232/RS485 – KR-01 converter
- AP2-1 – current loop unit
- K0047 – cigarette lighter cable

Remaining accessories

- stands for indicators

Dedicated Software

R-LAB

- collecting measurements
- carrying out statistical analysis of measurements
- customized graphs and reports

LabView Driver

- operation of RADWAG balances in LabView environment

Scale editor

- Software designed to enable change of parameters in the PUE C315 indicator.

Radwag Development Studio

- presentation of functions (and subfunctions) of communication protocol (Common Communication Protocol)
- possibility of connection with weighing equipment on which each function is carried out,
- library with mass control, contained within the development environment
- complete documentation of the communication protocol
- set of user manuals for different solutions addressed for programmers employed in companies using RADWAG-manufactured weighing equipment

R Panel

- operator access to all keys and functions that are to be found on an operation panel
- communication via COM1, COM2 or USB,
- compatible with: Windows Vista, 7, 8.1, 10, Server 2008R2, 2012, 2016.

RADWAG Connect

- establishing communication with all balances, scales and weighing modules using Common Communication Protocol
- communication via local network,
- support of basic functions
- auto searching for devices
- connecting with few devices simultaneously, swapping between them
- clear list of connected platforms
- record of measurements in the program,
- export of carried out measurements to CSV file,
- work performed using freely selected device with Windows 10 operating system

RAD KEY

- Establishing cooperation between a weighing instrument and a computer

R.Barcode

- The basic function software is presentation of the data sent by barcode scanners connected to PC via USB or RS23